

EX3G HMI PLC All-in-One User Manual

Thank you for purchasing Coolmay EX3G HMI PLC All-in-One products. This manual mainly explains the product features, specifications and wiring methods. Detailed PLC programming, please refer to "Coolmay EX3G HMI PLC All-in-One Programming Manual". Detailed HMI part, refer to "Coolmay HMI Programming Manual". The features are as below.

● Super functions.

Its PLC is compatible with FX3G, FX3U, FX3S. It operates fast.

● Highly integration.

- The digital points are 30 inputs and 30 outputs at most. The digital output can be transistor, relay or mixed output. Analog can reach up to 16 input and 8 output. It has 2 PLC COM port (RS232 and Mini B-type USB port), 1 downloading port and 1 USB port on HMI.
- The PLC part of models 70KH, 100HA all-in-one can optionally select one 485 port or two 485 ports (one is changed from existed 232 port). CAN, network port (not coexist with the one on HMI), Wifi (will cover the existed 232 port). The HMI part can optionally select one RS232 or one RS485, and network port (not coexist with the one on PLC).
- The PLC part of models 43HB, 43(50)KH can optionally select two RS485, and HMI part can select one RS232.

● Support several high-speed counting and high-speed pulse.

- Commonly high-speed counting is 6-channel single phase 60KHz or AB(Z) 2-channel 60KHz plus 1 channel 10KHz.
- High-speed pulse is commonly 8 channels, HB series Y0-Y7 10KHz per channel, Acceleration and deceleration are independent.
- The total high-speed counting and pulse can not exceed 480KHz.

● 32K steps program capacity, 32K power-off retentive registers, support interrupt, linear and circular interpolation, PID self-adjusting.

● Special encryption.

Set password as 12345678 to thoroughly prevent reading data. (PLC only supports 8-bit password encryption)

● PLC is compatible with Mitsubishi programming software, and HMI is Coolmay HMI programming software.

● More models are supported to customize if bulk order.

Product Details

◆ Naming rules EX3G - 43HB-24 M RT-4AD 2DA -V -A0 -1C1 -1P - 485P/232H

- Series EX3G
- HMI 43HB/43KH/43KHB: 4.3" 50KH: 5" 70KH: 7" 100HA: 10"
- Digital input and output (DI/DO) 10(5DI/5DO), 24(12DI/12DO), 44(24DI/20DO), 60(30DI/30DO), etc.
- Module type M- Main module of universal controller
- Digital output (DO) type R- relay T- transistor RT- both relay and transistor
- Analog input (AD) 4 channels for 43H, 12 for 70H/100H
- Analog output (DA) 2 channels for 43H, 8 for 70H/100H
- AI type E: Thermocouple E (can be customized as type K, T, S or J, supports negative temperature), PT: PT100, PT1000: PT1000, NTC: thermistor 10K, 50K, 100K
A0: 0-20mA A4: 4-20mA V: 0-10V V5: 0-5V
V5: -5V~5V V: -10V~10V (only 7 and 10 inch support V5_ and V_)
A0-0-20mA A4-4-20mA V-0-10V V5-0-5V
- AO type (only 70KH/100HA support negative voltage, covers 2 channels)
- C1- single phase high-speed counting, C2- AB phase counting, C3- ABZ phase counting.
Commonly for HB series, it is 6 single 10KHz, or 3 AB 10KHz, or 2 ABZ 10KHz + 1 AB 10KHz.
H/KH/HA series can be 6 single phase 60KHz, or 2 AB(Z) 60KHz + 1 AB 10KHz.
- P- high-speed pulse; Commonly EX3G-43HB is 8-channel 10KHz, and for other models, Y0-Y3 is 100KHz, Y4-Y7 is 10KHz. That high speed counting plus high speed pulse must be within 480KHz.
- Refer to "Chart 1: basic parameter".

◆ Basic parameter

Chart 1: basic parameter

Specifications of HMI PLC All-in-One	Digital points		Analog points (optional)		COM port (optional)		High-speed counting (optional)			High-speed pulse (optional)
	DI	DO	AD	DA	HMI	PLC	Single phase	AB phase	ABZ phase	Output
EX3G-43HB(H)/43(50)KH-16M	8	8	4	2	HMI PLC	PLC	H/KH/HA: 6-channel 60KHz	H/KH/HA: 2-channel 60KHz and 1-channel 10KHz	H/KH/HA: 2 ABZ 60KHz	H/KH/HA: H/KH/HA: Y0-Y3 is 100KHz, Y4-Y7 is 10KHz.
EX3G-43HB(H)/43(50)KH-24M	12	12	4	2						
EX3G-70H-16M	8	8								
EX3G-70H-24M	12	12	12	8						
EX3G-70H-38M	20	18								
EX3G-70H-44M	24	20	8	6						
EX3G-70KH/100HA-16M	8	8	16	8						
EX3G-70KH/100HA-24M	12	12	16	8						
EX3G-70KH/100HA-44M	24	20	16	8						
EX3G-70KH/100HA-60M	30	30	5	2						

EX3G-43HB(H)/43(50)KH: 1-232 port, 2-485 port, network port (can't coexist with the one on PLC).
EX3G-70KH/100HA: 1-232 port, 2-485 port, network port (can't coexist with the one on HMI), Wifi (cover the existed 232 port).
Acceleration and deceleration are independent.
High-speed counting and pulse can't over 480KHz.

EX3G-70KH/100HA: Max 5AD/2DA if 30DI/30DO.
Max 16AD/8DA if 24DI/20DO.

43HB (H)/43(50)KH: MT is MOS output, max load 2A.
70KH/100HA: MT is transistor output with max load 500mA. MR is relay output with max load 5A. MRT is mixed output.

Chart 2: electric parameter

Electric parameter	
Input voltage	DC24V
Digital input indexes	
Isolation mode	Photocoupling
Input impedance	High-speed input 3.3KΩ Common input 4.3KΩ

Input ON	High-speed input: current>5.8mA/24V Common input: current >9.9mA/24V
Input OFF	High-speed input: current<4.5mA/19V Common input: current >4mA/17V
Filter function	With filter function, the filter time can be set among 0-60ms, defaulted as 10ms
High-speed counting	Commonly for HB series, it is 6 single 10KHz, or 3 AB 10KHz, or 2 ABZ 10KHz + 1 AB 10KHz. H/KH/HA series can be 6 single phase 60KHz, or 2 AB(Z) 60KHz + 1 AB 10KHz.
Input level	Sink NPN, com isolation, S/S
Digital relay output index	
Max current	5A
Circuit power voltage	DC/AC 24V-220V
Circuit insulation	Relay mechanical insulation
On response time	Approx. 10ms
Mechanical life without load	10 million times
Electric life with rated load	300,000 times
Output level	Dry contact, COM connects positive or negative
Digital transistor(MOS) output index	
Max current	500mA(MOS 2A)
Circuit power voltage	DC24V
Circuit insulation	Optocoupler insulation
Isolated voltage (power-terminal)	1500VAC
On response time	High-speed output: 10 μs, and others 0.5ms
High-speed output frequency	8 channels, HB series Y0-Y7 10KHz per channel. H/KH/HA Y0-Y3 100KHz, Y4-Y7 10KHz. Acceleration and deceleration are independent. The total high-speed counting and pulse can not exceed 480KHz.
Output level	Low level NPN, COM connects negative
Analog input indexes	
Input signal	PT100/PT1000/thermocouple/NTC/0-10V/0-5V/-10V~10V/-5V~5V/0-20mA/4-20mA/ customizations.
Response time	1 scanning cycle
Analog input	0-16 channels
Precision	12 bits
Analog output indexes	
Output signal	0-5V/0-10V/0-20mA/ customizations
Analog output indexes	0-8 channels
Precision	12 bits
External port	
COM port	Refer to "Chart 1: basic parameter".
Environment	
Operating temperature	0°C~50°C
Relative humidity	5%~95%RH
Storage temperature	-20°C~70°C
Vibrational frequency	10-57Hz, amplitude 0.035mm, 57Hz-150Hz, 4.9m/s ² (10 times each on X, Y, Z, total 80 minutes each)

Mechanical Design

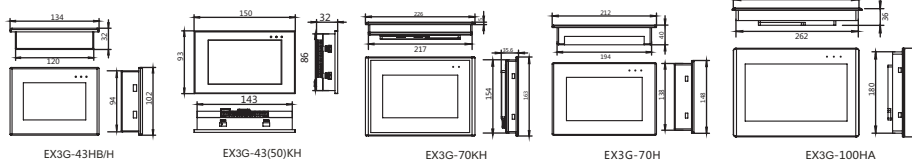

Graph 1 Mounting dimension

※ 更多规格批量客户可定制

※ More specs can be customized if bulk order.

Chart 3: Mounting dimension

Model	Max digital points	Max analog quantity	Mounting dimension		Boundary dimension W*H*D(mm)
			A(mm)	B(mm)	
EX3G-43HB	12DI/12DO	4AD/2DA	119	93	134*102*30
EX3G-43KH(50)KH	12DI/12DO	4AD/2DA	143	86	150*93*32
EX3G-70H	24DI/20DO	12AD/8DA	194	138	212*148*40
EX3G-70KH	30DI/30DO	16AD/8DA	217	154	226*163*35.6
EX3G-100HA	30DI/30DO	16AD/8DA	261	180	275*194*36

Electric Design

◆ Product structure

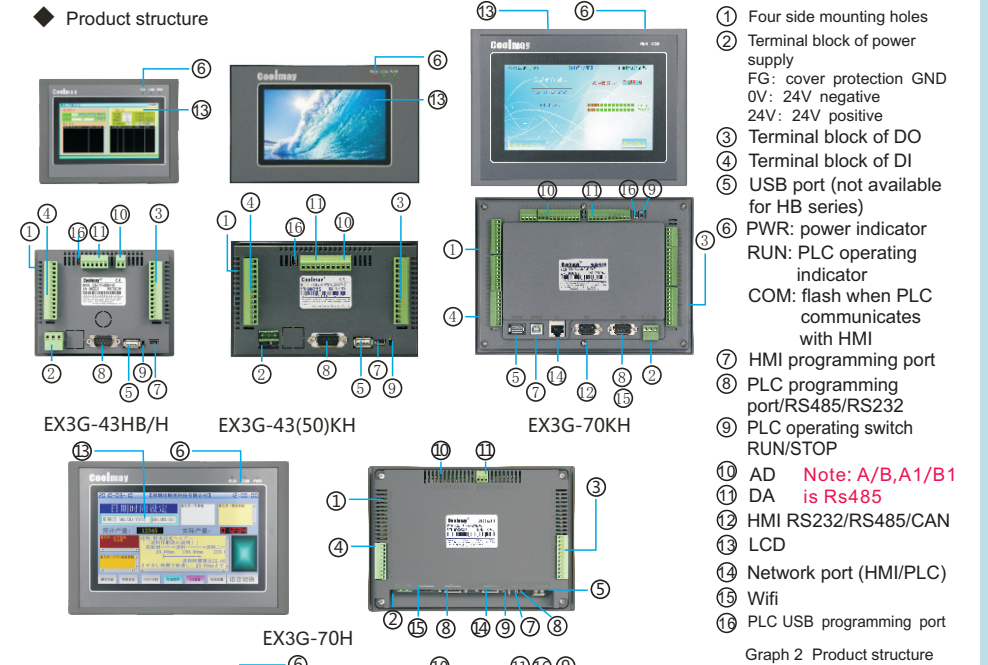

- Four side mounting holes
- Terminal block of power supply
FG: cover protection GND
0V: 24V negative
24V: 24V positive
- Terminal block of DO
- Terminal block of DI
- USB port (not available for HB series)
- PWR: power indicator
RUN: PLC operating indicator
COM: flash when PLC communicates with HMI
- HMI programming port
- PLC programming port/RS485/RS232
- PLC operating switch RUN/STOP
- AD
- DA
- HMI RS232/RS485/CAN
- LCD
- Network port (HMI/PLC)
- Wifi
- PLC USB programming port

Graph 2 Product structure

◆ Hardware Interface

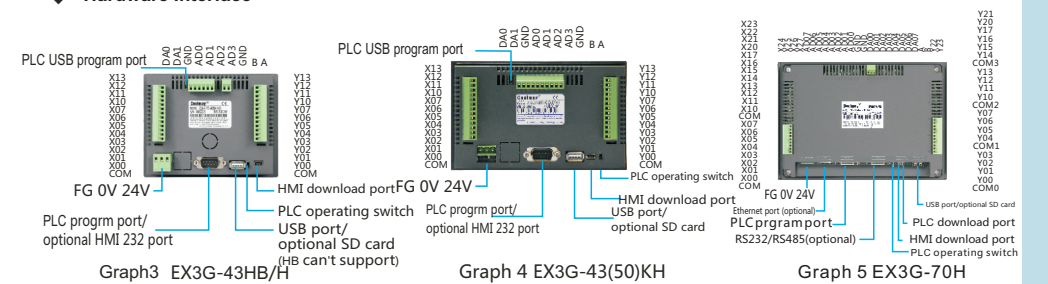

Graph 3 EX3G-43HB/H

Graph 4 EX3G-43(50)KH

Graph 5 EX3G-70H

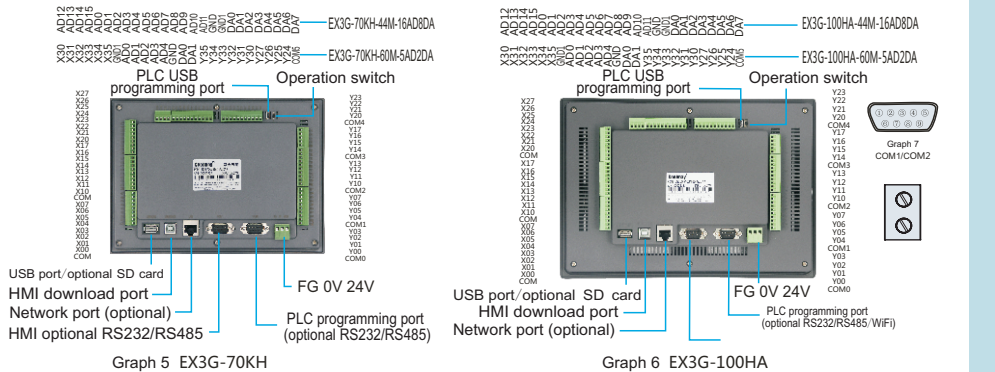

Graph 5 EX3G-70KH

Graph 6 EX3G-100HA

Wiring specifications of terminals: 22-14AWG wire. The terminals of this serial are all pluggable ones.

Definition of communication interface: Refer to Chart 4: Pin definition

Chart 4: Pin definition

EX3G-43HB/43H/43(50)KH all-in-one COM					EX3G-70H/70KH/100HA all-in-one COM(EX3G-70H can't support WIFI)								
COM1 DB9 port	Optional and default 232 cannot coexist	Optional	Default	Optional	COM2(DB9 port near power supply)				COM1(DB9 port away from power supply)			Network port	
PIN#	PLC-485-2 serial port 3	PLC-485-1 serial port 2	PLC-232 serial port 3	HMI-232	Db9 port	Optional	Optional and default 232 cannot coexist	Default	Optional and default 232 cannot coexist	Optional	Optional	Optional	Optional
1	√(485+)				1	√(485+)							
6	√(485-)				6	√(485-)							
2			√(RXD)		2			√(RXD)	√				
3			√(TXD)		3			√(TXD)	√				
5			√(GND)	√(GND)	5			√(GND)	√				
4			√(TXD)		4			√(TXD)	√				
7			√(RXD)		7								
8					8		√(485+)		√	√(H)			
9					9		√(485-)		√	√(L)			
Terminal 485		√											

* Note: Detailed settings, please refer to "Coolmay EX3G Programming Manual".

Equivalent Circuit

The PLC input (X) is an externally powered DC24V sinker (passive NPN) and the input signal is isolated from the power supply. Connect COM to positive 24V of external power supply while using. Figure 7 shows the equivalent circuit diagram of the relay output module. The output terminals are several groups and each group is electrically isolated. Different groups of output contacts are connected to different power circuits.

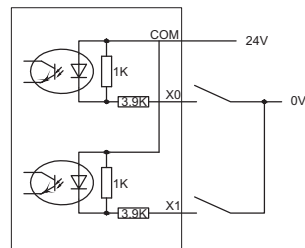

Figure 6 Input wiring

PLC digital inputs wiring:

Ports short circuit: S/S of PLC input terminal is connected to 24V, X terminal is connected to power supply 0V, i.e., input signal.
Two-wire system (magnetic control switch): The positive pole of the magnetic switch is connected to PLC X terminal, and the negative pole is connected to 0V.
Three-wire system (photoelectric sensor or encoder): Sensor or encoder power supply is connected to power supply positive, signal line is connected to X terminal. Encoder and photoelectric sensor are NPN type (PNP is customized).

PLC digital outputs wiring:

Transistor: Output is NPN, COM is connected to the negative pole, and Y is connected to the positive pole of the power supply with a load.
Relay: Dry contact output, COM can be connected to the positive or negative.

Figure 7 shows the equivalent circuit diagram of the relay output module. The output terminals are several groups and each group is electrically isolated. Different groups of output contacts are connected to different power circuits.

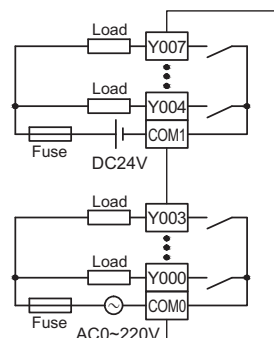

Figure 7 Equivalent circuit of relay output

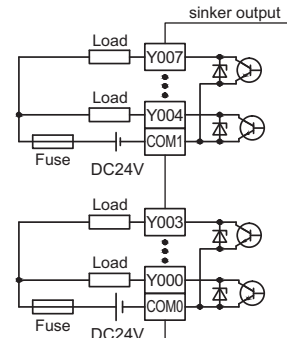

Figure 8 Equivalent circuit of transistor output

The equivalent circuit of the transistor PLC output is shown in Figure 8. Seen from the figure, the output terminals are several groups, and each group is electrically isolated, and different groups of output contacts can be connected to different power circuits. The transistor output can only be used for DC 24V load circuits. Output wiring is NPN, COM cathode.

For the inductive load connected to the AC circuit, the RC transient voltage absorption circuit should be considered on the external circuit. For the inductive load of the DC loop, adding a freewheeling diode should be considered, as shown in Figure 9.

Stepping or servo motor wiring is shown in Figure 10. 5V drive must connect a 2KΩ resistor on DC24V. 4-channel pulse are Y0, Y1, Y6, Y7, and customized 5-channel are Y0, Y1, Y6, Y7 and Y10.

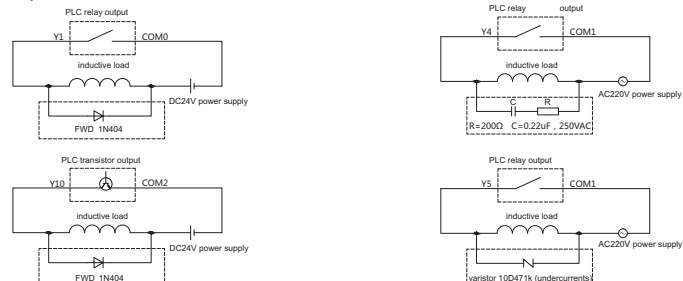
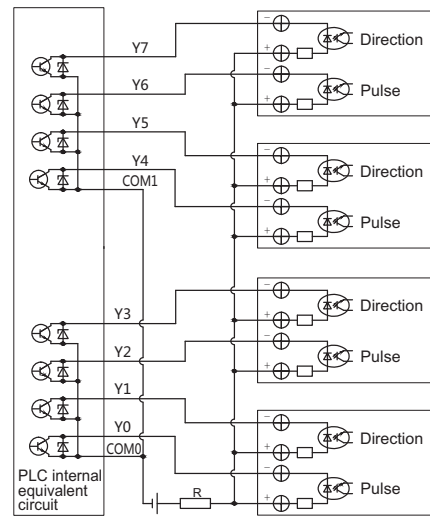

Figure 9 Inductive load absorption circuit



DC24V(5V drive must string 2kΩ resistor)

Figure 10 Pulse output wiring

※ Note: All internal circuit in the figure are taken as reference.

PLC analog wiring

Two-wire system: The positive pole of the power supply is connected to that of the transmitter, and the negative pole of the transmitter is connected to the AD side, and the negative pole of the power supply is connected to the GND. Generally it is the wiring method of the 4-20mA/0-20MA transmitter.
Three-wire system: The positive pole of the power supply is connected to that of the transmitter. The negative of the power supply and that of the signal output are the same terminal. The transmitter signal output is connected to the AD terminal.
Four-wire system: The positive and negative terminals of the power supply are connected to those of the transmitter respectively, and the positive and negative of the transmitter signal outputs are connected to the AD and the GND terminal respectively.
The two wires of the temperature analog are connected to the AD and the GND terminal respectively. If it is a three-wire PT100, it needs to be connected in two lines. The GND common terminal of the analog input and output can be shared.

PLC anti-jamming processing

1. Strong electricity and weak electricity should be separated wiring and not common ground. When there is strong electric interference, add magnetic ring on the power supply. And do correct and effective grounding according to the type of the chassis.
2. When the analog is disturbed, 104 ceramic capacitors can be added for filtering, and a correct and effective grounding can be performed.

* More details, please refer to "Methods of Coolmay PLC anti-jamming processing"

Programming reference

◆ Device allocation and power-down retention instructions

Max digital points	EX3G-43HB/43H/43(50)KH-24M	EX3G-70H-44M	EX3G-70KH/100HA-60M
DI X	X00-X13 12 points	X00-X27 24 points	X00-X35 30 points
DO Y	Y00-Y13 12 points	Y00-Y23 20points	Y00-Y35 30 points
Auxiliary relay M	[M0-M383] 384 points, general / [M384-M1535] 1152 points, maintain/ [M1536-M7679] 6144 points, general/ [M8000-M8511] 512 points, special		
Status S	[S0-S9] 10 points original state/ [S10-S999] 990 points, maintain/ [S1000-S4095] 3096 points, general		
Timer T	[T0-T199] 200 points, 100ms, general / [T250-T255] 6 points, 100ms, maintain/ [T246-T249] 4 points, 1ms accumulation, maintain / [T256-T319] 64 points, 1ms, general use/ [T200-T245] 46 points, 10ms, general use/ * 10ms timer is affected by scan cycle. If scan cycle is 12ms, the timer will work every 12ms.		
Counter C	16 bits increase counter(CTU)/32 bits increase and decrease counter (CTUD)/High speed counter [C0-C15] 16 points, general use/[C16-C199] 184 points, maintain use/[C200-C219] 20 points, general use/[C220-C234] 15 points, maintain use/[C235-C245 single phase single count], [C246-C250 single phase double count], [C251-C255 double phase double count]		
Data register D	[D0-D127] 128 points, general / [D128-D7999] 7872 points, maintain / [D8000-D8511] 512 points, special use		
Data register V,Z	[V0-V7] [Z0-Z7] 16 points, used while modifying address		
Extended file register R	[R0-R22999] 23000 points, support power retentive/ [R23000~R23999] 1000 points, system internal use		
Pointer JUMP, CALL branch use	[P0-P255] 256 points/ [P0-P1280] 1281 points (26232 and higher version)		
Nested pointer	[N0-N7] 8 points, master use		
Interruption	[I0□-I5□] 6 points, input interruption use/ [I6□-I8□] 3 points, timer interruption use/ [I10□-I60□] 6 points, timer interruption use		
Constant	K	16 bits -32,768-32,767 / 32 bits -2,147,483,648-2,147,483,647	
	H	16 bits 0-FFFFH/32 bits 0-FFFFFFFFH	

◆ Analog input register (AD, accuracy 12 bits). Support FROM demand or register read directly.

FROM demand read: FROM K0 K0 D400 K16 can be read as 16-channel analog inputs.

Registers read directly: D[8030]-D[8045] are the input values of [AD0~AD15]. The constant scan-time will change to D8059 and started by M8039 (version 26232 and higher). It supports max 15 analog inputs when there exist thermocouple type, and AD4[D8034] is the ambient temperature of thermocouples. It supports max 16 analog inputs without thermocouples.

※ The temperature type is one digit after the decimal point, i.e. 182 = 18.2 degrees.

※ Note: Analog input range and register values, please refer to "Coolmay EX3G HMI PLC All-in-One Programming Manual".

*1 Please consider adding 104p ceramic capacitor or external magnetic ring filter to increase anti-interference ability if analog inputs are unstable.

* Analog input is AD0-AD15 and output is DA0-DA7 are connected to GND input and output respectively.

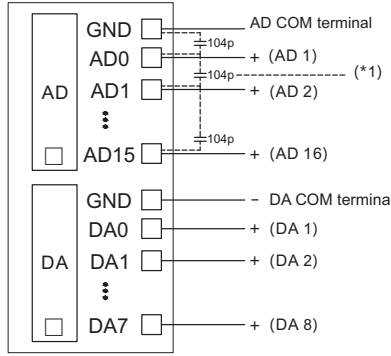

Figure 11 PLC analog wiring

※ AD sampling

Filter cycles = (R23600~R23615)* scan time of the PLC. The default value is 100 and the data cannot be less than or equal to zero. If R23600=1, one PLC scan cycle samples once, and the value in the first analog input is changed once. The larger the value of R23600~R23615 is set, the more stable the result is.

D8073 is the smoothing filter coefficient of all analog inputs. The setting range is 0~999.

◆ Analog output register (DA, accuracy 12 bits). Support TO demand or direct register assignment.

TO demand direct outputs: TO K0 K0 D500 K8, 8 analog outputs

TO demand direct outputs: D[8050]~D[8057] correspond to the values of [DA0~DA7]. When select negative outputs, 2 analog outputs will be covered. The configuration is as the chart below.

No	Register address	Range of set value	Output type
DA0	D8050	0-4000	If D8058.0~D8058.7=0, output type is 0-20mA.
DA1	D8051	0-4000	
DA2	D8052	0-4000	
DA3	D8053	0-4000	
DA4	D8054	0-4000	If D8058.0~D8058.7=1, the type is 4-20mA.
DA5	D8055	0-4000	
DA6	D8056	0-4000	
DA7	D8057	0-4000	

The soft elements power retentive of HMI PLC all-in-one is permanently retentive, i.e., all the soft elements in the holding area are not lost if the module is powered off. The real-time clock uses a rechargeable battery to ensure that the clock is the current time. All power retentive functions must ensure that the voltage is 23V or higher when DC24V power supply with loads, and the PLC power-on time is longer than 2 minutes. Otherwise, the power retentive functions will be abnormal.

* Programming software

PLC: compatible with Mitsubishi PLC programming software GX WORKS 2.
HMI: Coolmay HMI programming software

* Detailed information, please refer to

"Coolmay EX3G HMI PLC All-in-One Programming Manual",
"EX3G HMI PLC All-in-One User Manual",
"Coolmay HMI User Manual",
"Mitsubishi FX3G Programming Manual"

TIPS

EX3G HMI PLC All-in-One User Manual

— Please read carefully the related manuals before using our products, and use this product under the environmental conditions specified in this manual.

1. Power on after confirmed the voltage (24VDC, >18W) and right wiring to avoid damage.
2. Tighten the screws or the rail while mounting the product to avoid falling off.
3. Avoid wiring or plug the cable with electricity, or it is easy to cause electric shock or circuit damage. When the product emits odor or abnormal sound, please immediately switch off the power. While processing screw holes or wiring, do not drop the metal chips and wire head into the ventilation hole of the controller, which may cause product failure and disoperation.
4. Do not tie power cables and communication cables together or close and keep them at a distance of 10cm or more. Strong and weak currents need to be separated and correctly grounded. In severe interference situations, input and output cables of the communication and high-frequency signals should use shielded cables to improve anti-jamming performance. The grounding terminal FG on this unit must be properly grounded to improve the anti-interference ability.
5. DI is an externally powered DC24V sinker (passive NPN), and the input signal is isolated from the power supply. Connect S/S to 24V of external power supply while using.
6. DO (transistor) COM is common cathode.
7. Please do not disassemble the product or change the wiring. Or it will possible to cause breakdown, malfunction, loss, or fire.
8. While installing or disassembling the product, ensure to turn off all power. Or it may cause malfunction and breakdown.

Catalog

Shenzhen Coolmay Technology Co., Ltd

Tel.: 0755-86950416

86960332

26051858

26400661

Fax: 0755-26400661-808

QQ: 800053919

Email: 800053919@b.qq.com

Website: www.coolmayplc.com

Version: 2019/8

Tips.....01

Product Features.....02

Product Information.....03

Electric Parameter.....04

Mechanical Design.....05

Electric Design.....06

Equivalent circuit.....07

Analog Wiring.....08

Anti-interference Processing.....09

Programming Reference.....10

Data Reference.....11